



Energy Recovery Hydropower

80 kW, 193 Feet, 6.5 CFS
Fort Collins, CO

Generate Power from New and Existing Water Delivery Networks

Canyon Hydro offers complete hydroelectric equipment packages for in-conduit energy recovery applications.

Potential generation sites may be found in any raw, drinking, or waste water network. The electricity generated can be used on-site to offset facility needs or sold to local utilities for profit.

Common applications are at flow or pressure control locations. Standard equipment packages include all components required to recover lost energy.



48 kW, 220 Feet, 3.3 CFS
Covington, WA



95 kW, 170 Feet, 8.5 CFS
Layton, UT

Complete Customizable Systems

Canyon Hydro's Pump Turbine Systems are specifically designed for conduit energy recovery applications. These fixed flow turbine-generator packages are skid mounted for simple installation and integrate seamlessly into both new and existing water delivery networks.

Simplified Integration

- All Required Components Included
- Compatible with Any Existing SCADA System
- Controls Configured to Customer Specification
- Multiple Turbine Sizes for Standard Pipe Diameters
- Interconnection for Local Utility Requirements

Worry Free Operation

- Water Delivery Always Prioritized
- Smooth Startup and Shutdown
- Secure Remote and Local Operation
- Utility Grade Controls and Interconnection
- Fail-Safe Configuration Standard
- System Battery Backup Available

Available System Services

- Mechanical Installation by Canyon Hydro Millwrights
- Equipment Start-up, Testing, Commissioning and Training
- Ongoing Phone Support and Troubleshooting *
- Standard 1-Year Equipment Warranty *
- Optional 2-Year Equipment Warranty
- Maintenance Contracts

* Included with purchase



80 kW, 193 Feet, 6.5 CFS
Fort Collins, CO

Pump Turbines Examples

Turbine Model*	Speed (RPM)	Net Head (Feet)	Flow Rate (CFS)	Power Output (Range)
10 TR2	1800	125 - 300	11.0 - 18.0	85 - 335 kW
	1200	50 - 125	6.5 - 11.5	18 - 90 kW
10 TR1	1800	65 - 160	9.5 - 14.5	35 - 135 kW
	1200	30 - 90	6.5 - 10.5	10 - 54 kW
8 TR3	1800	170 - 425	6.5 - 13.5	70 - 360 kW
	1200	80 - 190	5.0 - 9.0	20 - 105 kW
6 TR4	1800	220 - 390	4.5 - 9.5	55 - 240 kW
	1200	100 - 190	3.5 - 6.5	20 - 75 kW
6 TR3	1800	180 - 440	4.0 - 8.5	40 - 220 kW
	1200	80 - 190	2.5 - 5.5	10 - 60 kW
5 TR5A	1800	50 - 120	2.8 - 4.6	8 - 35 kW
	1200	25 - 55	2.0 - 3.2	3 - 12 kW
5 TR4	1800	225 - 500	3.5 - 7.0	40 - 215 kW
	1200	110 - 210	2.6 - 4.6	15 - 60 kW

NOTE: - Pump turbines are fixed flow hydroelectric generators
 - Flow rate for each model is dependent on available net head
 - Power output is a product of available net head and flow rate
 - Additional models and speeds are available

*Please contact Canyon Hydro for assistance with selection of the best option for your site and project

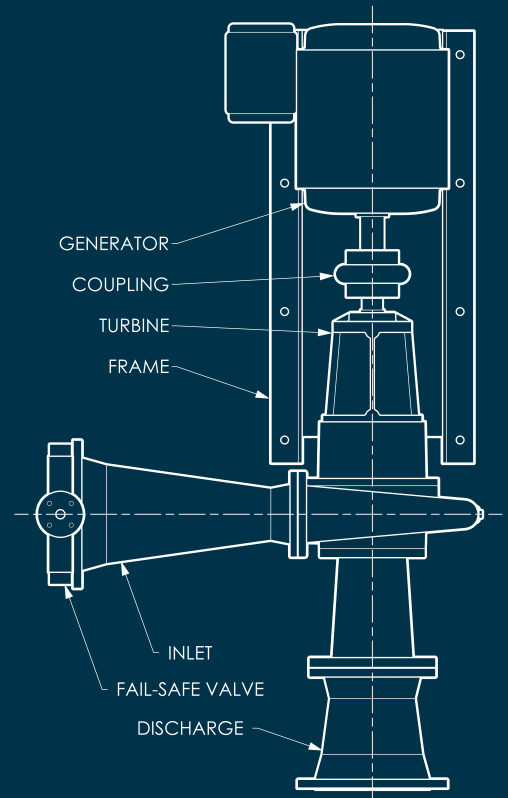

Plan View

Control and Interconnection Equipment

Standard control systems are available for most systems in either a wall mounted configuration. Wall mounted configurations require less space however have less room for manual controls and auxiliary displays.

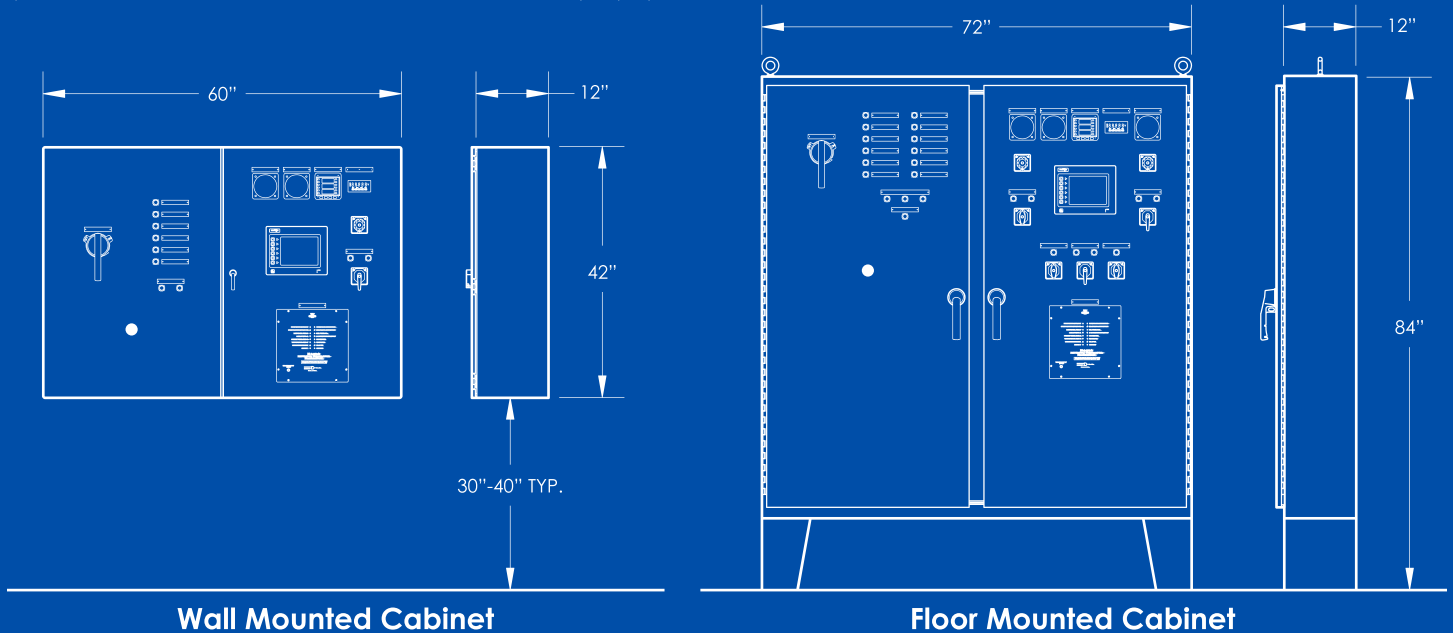

Wall Mounted Cabinet

Floor Mounted Cabinet

Pump Turbine Technology

Manufactured in the USA, Canyon Hydro's Pump Turbines are of fixed flow Francis design. These turbines are familiar to water facility operators and maintenance personnel as they are modified centrifugal pumps operating in reverse.

Pump Turbine equipment packages are simple to install, operate and maintain. The turbine, generator, hydraulic power unit and drive assembly arrive on site pre-installed to a custom structural steel mounting frame. Inlet and outlet transitions are designed and manufactured to meet existing upstream and downstream flange requirements. A fail-safe inlet valve and actuator arrive preassembled and ready to install. Custom switchgear and controls panels are designed and built in the USA to meet the unique requirements of each electrical utility and project.

PAT systems are intended to operate in parallel with existing pressure reduction valves. Since Pump Turbines operate at a fixed flow rate, the parallel PRV passes any required flow beyond the turbine's capacity. The existing PRV additionally serves as a full flow bypass if the turbine is not in operation.



74 kW, 317 Feet, 3.8 CFS
Hillsboro, OR

1-360-592-5552
info@canyonhydro.com

5500 Blue Heron Ln., Deming, WA 98244 USA

